

REVISIONS				
REV.	DATE	DESCRIPTION	ECO	BY
A	04-18-07	PRODUCTION RELEASE	11573	DN
B	07-18-07	REPLACED 050-1979 W 050-2047, CHANGED TO B SIZE, ADDED 050-2095	11650	DN

VIEWES ARE FOR BADGE LOCATION REFERENCE ONLY

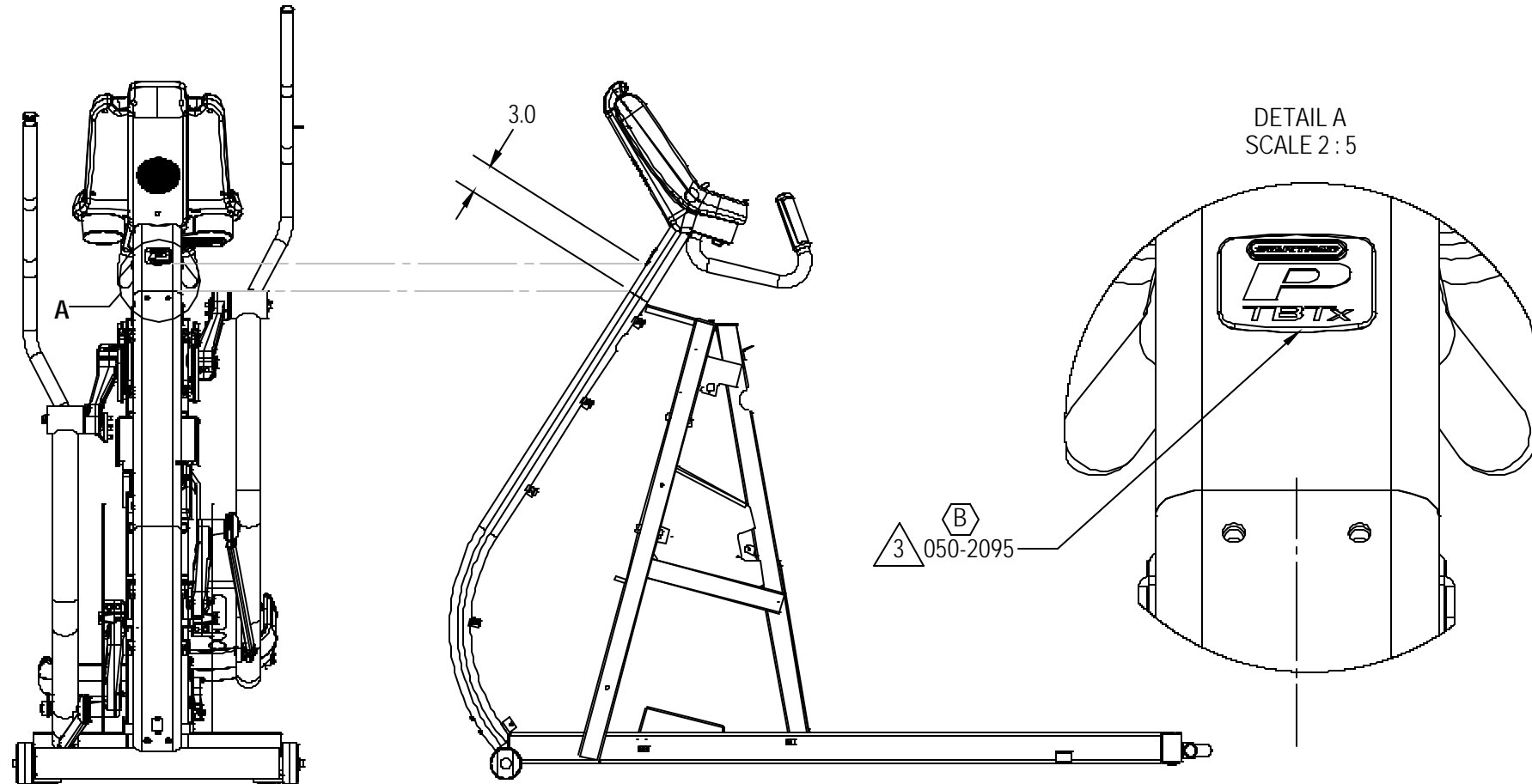

- NOTES:**
- SERIAL LABEL INFORMATION:
 - VOLTS: 12 VDC
 - AMPS: 1.0 A
 - CYCLES: N/A
 - WATTS: 12 W
 - PHASE: N/A
 - IPX #: IPX 1
 - CERTIFICATION LOGOS:
 - CSA
 - CE
- CLEAN AREA WITH ISOPROPYL ALCOLHOL PRIOR TO PLACING BADGE.**

**DOCUMENT STATUS:
RELEASE**

NOTICE OF PROPRIETARY INFORMATION
THIS DOCUMENT SHALL NOT BE REPRODUCED NOR SHALL THE INFORMATION CONTAINED HEREIN BE USED BY OR DISCLOSED TO OTHER EXCEPT AS EXPRESSLY AUTHORIZED BY UNISEN

ITEM	PART NUMBER	DESCRIPTION	QTY	
1	050-1964	TAG, TORQUE, HANDLEBAR	1	
B	2	050-2047	ASSY, PACKAGING, TBT	1
B	3	050-2095	BADGE, PRODUCT, P-TBTX	1
4	620-7522	DHF, ROYAL TRAIN, 6100-6200	0	
5	721-0134	KIT, HARDWARE, CT	1	
6	721-1150	ASSY, FRAME, P-TBTx	1	
7	721-1151	ASSY, UB LINKAGES & LEGS, P-TBTx	1	
8	721-1152	ASSY, SHROUD, P-TBTx	1	

MATERIAL
SEE BOM

FINISH
N/A

VENDOR:

P/N:

TOLERANCES UNLESS OTHERWISE SPECIFIED
X.XXX = ± .010" (0.25MM) ANGLES = ± 2°
X.XX = ± .030" (0.76MM) FRACTIONS = ± 1/32
X.X = ± .050" (1.27MM)
X = ± .125" (3.20)

UNISEN, INC. DBA 14410 Myford Road
Irvine CA 92606
STAR TRAC

INITIAL DATE
DRAWN DN 06-11-07
CHECKED
APPROVED

PART NO
9-6230-MINTPO REV **B**

TITLE
P-TBTX6200, S/P, M, INT

U.O.M. INCH SCALE: 1:15 SHEET 1 OF 1 SHEET SIZE: B